

# INNO 100

VERTICAL

## THE MOST COMPACT BALER IN THE RANGE

INNO 100 is a compact baler with a large feed opening and thanks to the dual scissor action hydraulic cylinders, it is low-built and easy to place on your premises. Model 100 features an easy-to-use touch screen.



## Compact design

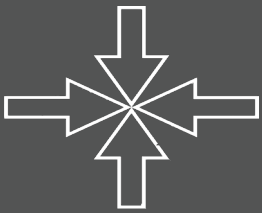

100

BALE WEIGHT (UP TO)  
CARDBOARD

## Expertise through experience

**PRESSOR** is a market leading manufacturer of high quality compaction equipment. We offer you a complete range of equipment for collecting and compacting recyclables and waste. Partner up with us. We are there for you all the way!



## Benefits for you

- + Save time and increase productivity!
- + Gain valuable floor space!
- + Optimize logistics! Reduce transportation costs!
- + Safe and comfortable working environment
- + More profitable waste management and increased income from sales of recyclables

# INNO 100

## Compact baler with large infeed

### OPTIMIZED FOR:

#### PAPER

+ Cardboard

#### PLASTIC

+ Shrink film

### VERSATILE AND RESILIENT BALER

Our tough and robust baler has a strong construction, a long service life and many application areas.

### SINGLE PHASE

INNO 100 is a single phase unit, which makes it easy to place in different businesses and environments.

### SEMI-AUTOMATIC BALING

The manual bale binding by strap or wire is a simple procedure and the when pushing the buttons on the side of the machine, the baler automatically ejects the bale.

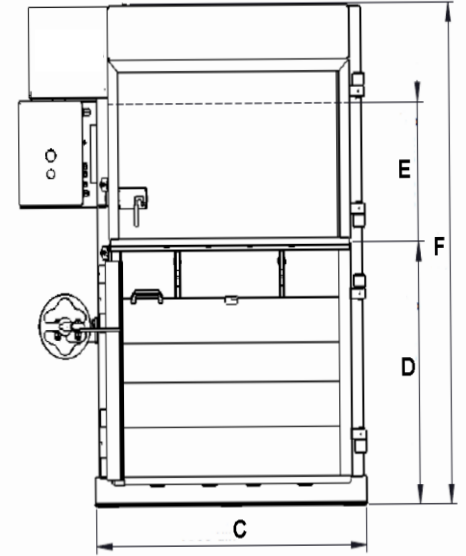
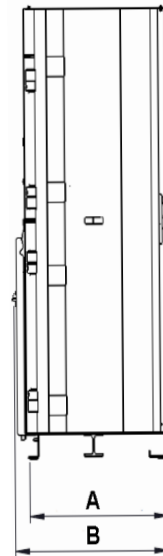

## DIMENSIONS & SPECIFICATIONS

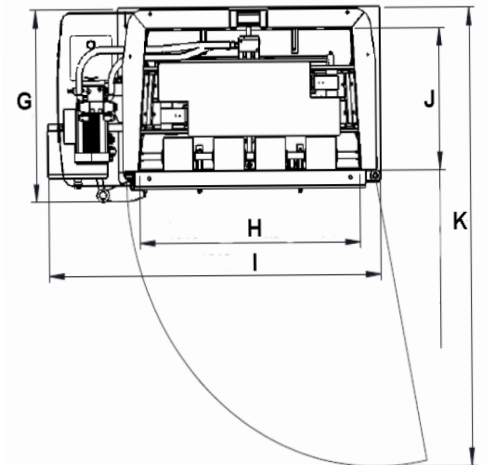

### DIMENSIONS

| A      | B      | C       | D       | E      | F       |
|--------|--------|---------|---------|--------|---------|
| 740 mm | 818 mm | 1300 mm | 1021 mm | 550 mm | 1950 mm |

### DIMENSIONS

| G      | H       | I       | J      | K       | Transport height |
|--------|---------|---------|--------|---------|------------------|
| 818 mm | 1050 mm | 1612 mm | 600 mm | 1951 mm | 1950 mm          |

### TECHNICAL SPECIFICATIONS

| LOADING APERTURE                 | CYCLE TIME | PRESS FORCE    | BALE SIZE                      | BALE WEIGHT                   | RAM SURFACE                                       | MOTOR                  | MACHINE WEIGHT |
|----------------------------------|------------|----------------|--------------------------------|-------------------------------|---|------------------------|----------------|
| Width: 1050 mm<br>Height: 550 mm | 43 secs    | 10 ton, 100 kN | HxWxD:<br>1000 x 1050 x 600 mm | Cardboard:<br>up to 70-100 kg | 1000 x 600 mm                                     | 1.5 kW<br>single phase | 805 kg         |
|                                  |            |                |                                |                               | <b>SURFACE PRESSURE</b><br>1.7 kg/cm <sup>2</sup> |                        |                |

We reserve the right to make changes to specifications without prior notice. Bale weights are dependent upon material type.